



### One of the most flexible trucks on the market. Ideal for routes that require both manual and automated pickup.

- Combines a side arm for automated collection and a low-height hopper for easy manual loading.
- With an arm reach of 6 feet, lift capacity of 500 pounds, smooth operation and one-button pickup, it can handle cans of almost any size.
- Low sill height for easy loading of the “extras;” optional cart tippers allow collection from both sides of the street. Plus, a simple-to-operate tilt dump body.
- Arm and packer operation at idle speed keeps noise to a minimum.
- Use it as a strictly manual side loader. With its drop frame and curbside hopper, it's ideal for single-man routes.
- Excalibre™ cylinders feature hardened nitrided rods and a tool shaver that help keep refuse debris out, reducing hydraulic contamination.

#### PERFORMANCE SPECIFICATIONS (in seconds)\*

##### WORKING RPM @ IDLE

Arm In	2-1/2
Arm Out	3-1/2
Arm Up	2-1/2
Arm Down	2-1/2
Grabber Open	1
Grabber Closed	1
Packer Extend	8
Packer Retract	3-1/2
Pack Assist Up	2-1/2
Pack Assist Down	1-1/2
Tailgate Open	17
Tailgate Closed	21
Body Up	28
Body Down	50

\*Cycle times may vary slightly

#### ARM ASSEMBLY

Arm Reach	6 ft
Arm Lifting Capacity	500 lb

#### HOPPER SPECIFICATIONS

Hopper Capacity	2.7 cu yd
Hopper Floor	3/16 in. AR 450
Hopper Floor Wear Area	1/4 in. AR 200

#### PACKER/EJECTOR SPECIFICATIONS

Packing Face	1/4 in. AR200
Wear Strips	X-Wear and AR400
Follower Panels	3/16 in. AR200

#### BODY SPECIFICATIONS

Body Floor	10-gauge AR200
Side Walls	10-gauge AR200
Roof	12-gauge ASTM A1011/ A1018 Grade 50

#### TAILGATE SPECIFICATIONS

Tailgate Side Walls	1/8 in. AR450
Tailgate Rear Wall	1/8 in. AR450

#### OPERATIONS

Multiplexed and distributed CAN-based controls offering world class technology and features (sealed keypads, backlit screens, operator status lights and diagnostic display)

#### HYDRAULICS

Pump	Tandem pump with HOC and pack-on-the-go flow control system
Packer Valve	Parker VA35 x 2 work sections—pneumatic operating with pre-coalescing filter
Arm Valve	Parker P70 x 5 work sections—electric proportional coils
Oil Reservoir	50 gallon
Filter	40 mesh suction filter
5 Micron Medium-Pressure Return Line	

#### CYLINDERS

Packer Cylinder	4 in. bore x 3 in. rod x 39-1/2 in. stroke
Tailgate Cylinder	2-1/2 in. bore x 1-1/2 in. rod x 38 in. stroke
Arm In/Out Cylinders	2 in. bore x 1-1/4 in. rod x 67 in. stroke
Grabber Cylinder	2 in. bore x 1 in. rod x 6-1/4 in. stroke

#### PAINTING

Packer and components steel shot blasted prior to priming with high solids epoxy primer  
Finish: PPG high performance, high solids acrylic urethane topcoat

#### McNEILUS WARRANTIES

Contact your McNeilus representative on warranty details.  
For more information, go to [www.McNeilusGarbageTrucks.com](http://www.McNeilusGarbageTrucks.com)

# MANUAL/AUTOMATED SIDE LOADER

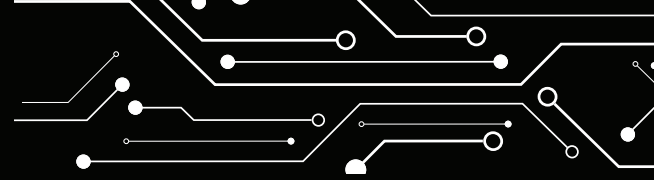

- McNeilus CNG Systems and Service offers compressed natural gas systems in a variety of configurations and capacities for the Manual/Automated Side Loader.
- Multiplexed and CAN-based controls are one of the most advanced, and easy to use in the industry, with operator status display and full diagnostics.
- High-quality abrasion-resistant steel in all high-wear areas for outstanding strength and durability.
- McNeilus partners with top equipment dealers across North America to provide best-in-class support and access to service and parts close to home.
- Proudly made in the USA.

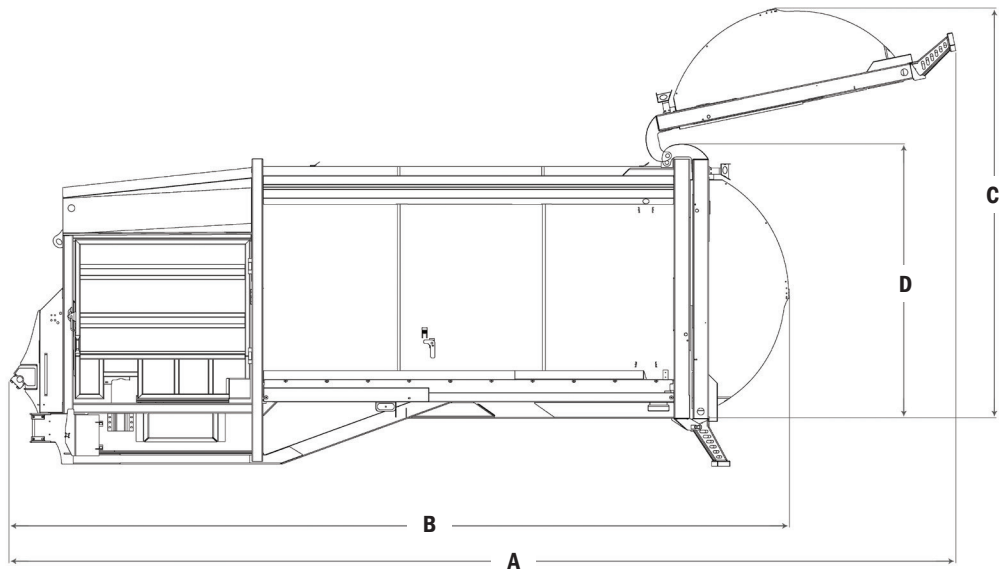

DIMENSIONS						
DESCRIPTION	26 YD (19.9 M)		28 YD (21.4 M)		31 YD (23.7 M)	
(A) Overall Length, Tailgate Open	347 in.	8814 mm	361 in.	9169 mm	347 in.	8814 mm
(B) Overall Length, Tailgate Closed	279 in.	7087 mm	299 in.	7595 mm	296 in.	7518 mm
(C) Height: Tailgate Open	145 in.	3683 mm	145 in.	3683 mm	163 in.	4140 mm
(D) Height: Tailgate Closed	100 in.	2540 mm	100 in.	2540 mm	108 in.	2743 mm
Overall Width: Arm Stowed	96 in.	2438 mm	96 in.	2438 mm	96 in.	2438 mm
Minimum Dump Radius	42 in.	1067 mm	42 in.	1067 mm	42 in.	1067 mm
Minimum Alley Width	152 in.	3861 mm	152 in.	3861 mm	152 in.	3861 mm
Grabber Height from Ground	10 in.	254 mm	10 in.	254 mm	10 in.	254 mm

Note: Dimensions will change with roof-mounted CNG options.



We offer a complete line of aftermarket parts and services to fit all makes and models. View and purchase at [www.StreetSmartParts.com](http://www.StreetSmartParts.com) or call 888.686.7278.



Learn more at [www.McNeilusGarbageTrucks.com](http://www.McNeilusGarbageTrucks.com) | [StreetSmartParts.com](http://StreetSmartParts.com)

© 2024 McNeilus Truck and Manufacturing. McNeilus, the McNeilus logo, Street Smart Parts and the Street Smart Parts logo are trademarks of McNeilus Truck and Manufacturing, Dodge Center, MN, USA. All other designated trademarks are the property of their respective owners. Specifications, descriptions and illustrations in this brochure are accurate as shown at the time of publication, but are subject to change without notice. Illustrations may include optional equipment and accessories and may not include all standard equipment.